

Transmission Type ..... 240E/240L/241/A244E/A245E/A246E

Rebuilder's Kwik  
Reference Guide



### Clutch Clearances

Forward Clutch\* ..... .050-.065" ..... Pressure Plate  
**Intermediate Clutch**  
 Direct Clutch\* ..... .045-.060" ..... Pressure Plate  
 Low/Reverse Clutch\* ..... .047-.087" ..... Not Adjust.  
**Reverse Clutch**  
**Overrun Clutch**  
 Underdrive Brake Clutch ... .045-.078" ..... Not Adjust.  
 Underdrive Clutch ..... .050-.065" ..... Pressure Plate  
 \*Piston Stroke

### Adjusted By:

### Torque Specifications

Pump Halves ..... 84 In. Lbs.  
 Pump To Case ..... 18 Ft. Lbs.  
 Valve Body Halves ..... 56 In. Lbs.  
 Valve Body To Case ..... 84 In. Lbs.  
**Chain Cover To Case**  
 Pan ..... 43 In. Lbs.  
**Center Support**  
**Extension Housing**  
**Driven Sprocket Support**  
**Overdrive Support**  
**Chain Cover**  
 Transfer Gears ..... 116 Ft. Lbs.  
**Governor Bolts**  
 Bellhousing To Main Case ..... 22 Ft. Lbs.  
**Idler Nut**  
 Endcover Bolts ..... 22 Ft. Lbs.

### Band Adjustment

**Intermediate Band**  
**2-4 Band**  
**Low/Reverse Band**  
**Overdrive Band**  
 2nd Manual Band ..... .059-.118" ..... Servo Pin

### Unit Endplays

### Location

### Selective

Front Unit .012-.035" ..... Stator ..... Bearing Race  
 Differential:  
 Preload 7-13 In. Lbs. New Bearings ..... Under Bearing Race ..... Shim  
 Preload 3-6 In. Lbs. Used Bearings ..... Under Bearing Race ..... Shim  
 Countershaft Endplay .009-.035" ..... In Case ..... Not Adjustable  
 Countershaft Assembly:  
 Preload 6-8 In. Lbs. New Bearings ..... Crush Collar  
 Preload 2-4 In. Lbs. Used Bearings ..... Crush Collar

Transmission Type ..... 240E/240L/241/A244E/A245E/A246E

Rebuilder's Kwik  
Reference Guide



## Clutch & Band/Solenoid Application Charts

Gear		Forward Clutch	Direct Clutch	U/D Clutch	2nd Coast Brake	2nd Brake	Low/Reverse Brake	U/D Brake	#1 1-Way Clutch	#2 1-Way Clutch	U/D 1-Way Clutch
Reverse			Applied				Applied	Applied			
D	1st	Applied						Applied		Applied	Applied
	2nd	Applied				Applied		Applied	Applied		Applied
	3rd	Applied	Applied			Applied		Applied			Applied
	O/D	Applied	Applied	Applied		Applied					
2	1st	Applied						Applied		Applied	Applied
	2nd	Applied			Applied	Applied		Applied	Applied		Applied
	3rd	Applied	Applied			Applied		Applied			Applied
1	1st	Applied					Applied	Applied		Applied	Applied
	2nd	Applied			Applied	Applied		Applied	Applied		Applied

Solenoid Application Chart		
Gear	Solenoid 1	Solenoid 2
1st	On	Off
2nd	On	On
3rd	Off	On
4th	Off	Off

Transmission Type ..... 240E/240L/241/A244E/A245E/A246E

Rebuilder's Kwik  
Reference Guide



## Technical Tips For Rebuilding For This Unit

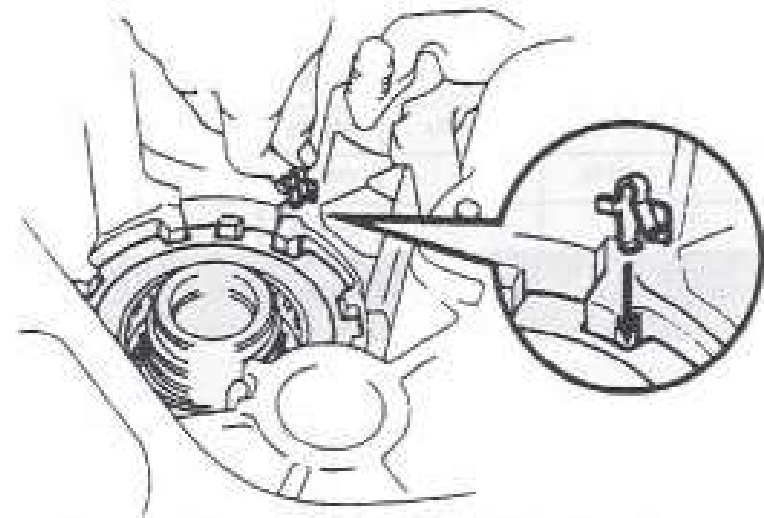
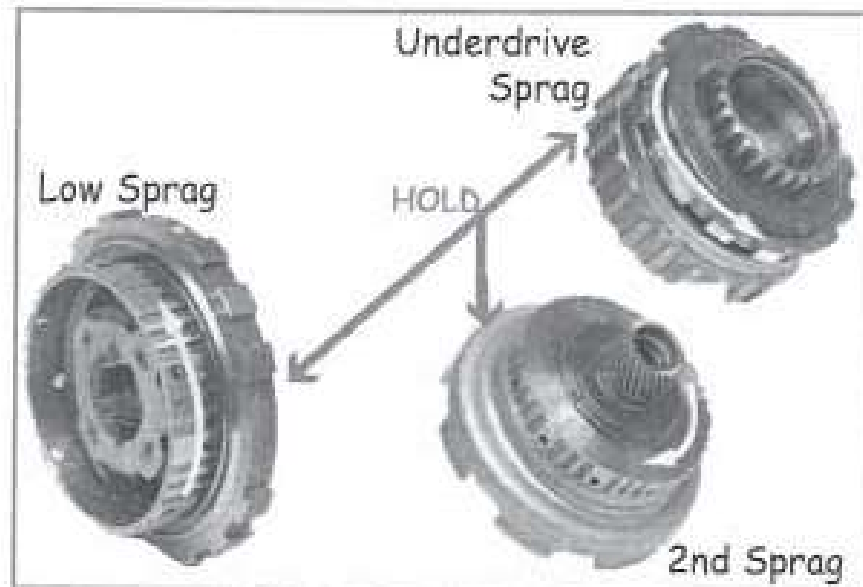

Installing Anti-Rattle Clip (Clicks in Place)

Transmission Type ..... 240E/240L/241/A244E/A245E/A246E

# Rebuilder's Kwik Reference Guide



## Solenoid & Harness Information

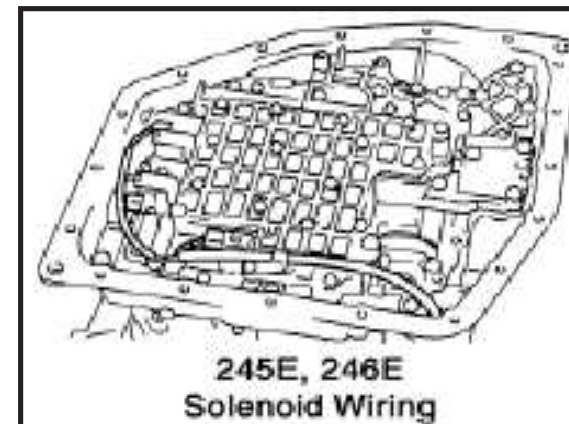
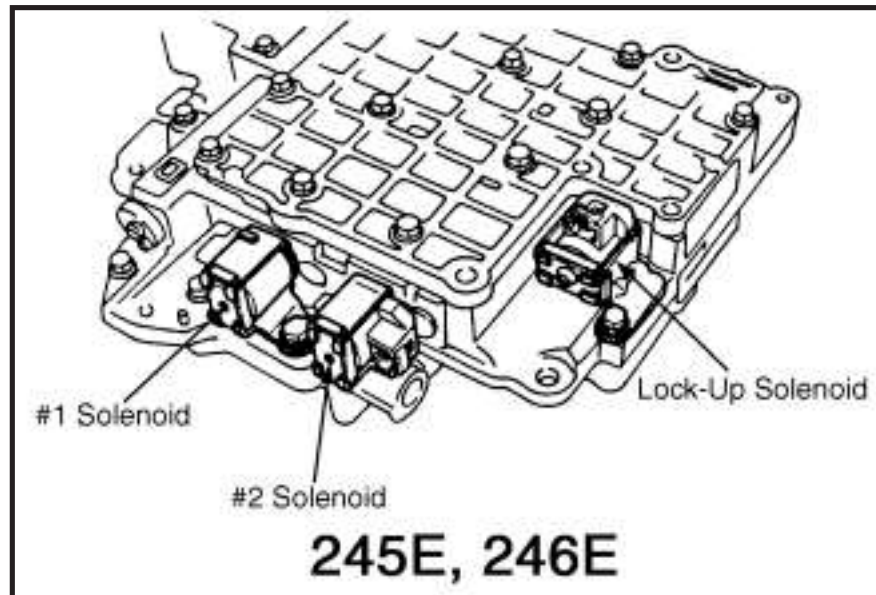
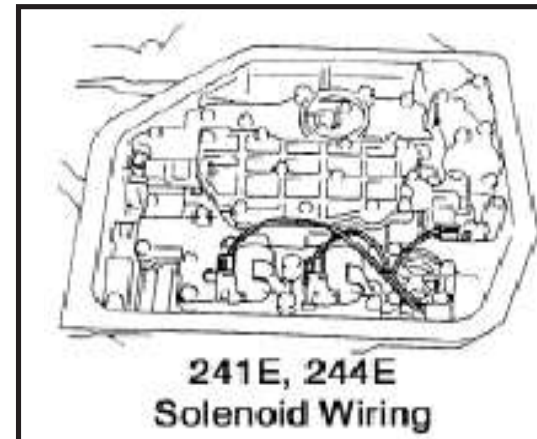
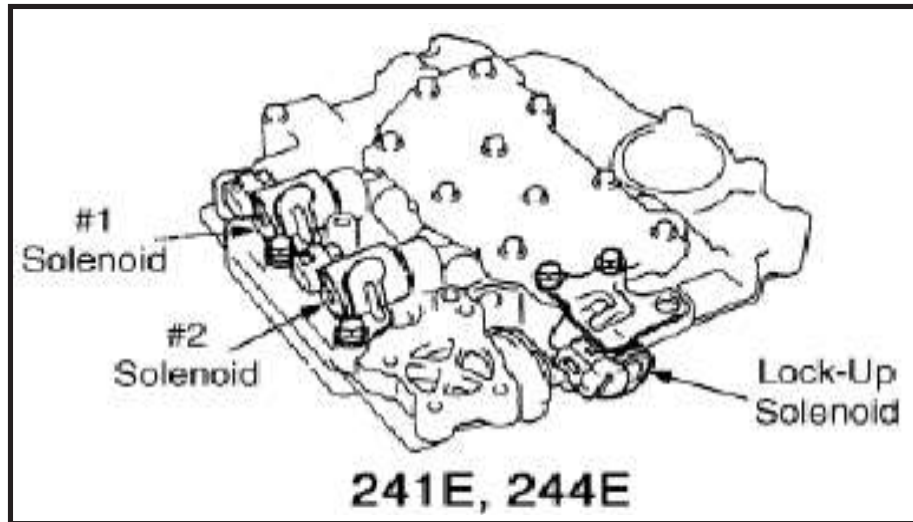

Solenoid	Resistance
Solenoid #1	11 - 15 Ohms
Solenoid #2	11 - 15 Ohms
Lock-Up	11 - 15 Ohms

Transmission Type ..... 240E/240L/241/A244E/A245E/A246E

Rebuilder's Kwik  
Reference Guide



### Checkball Locations 240E 1985-Later

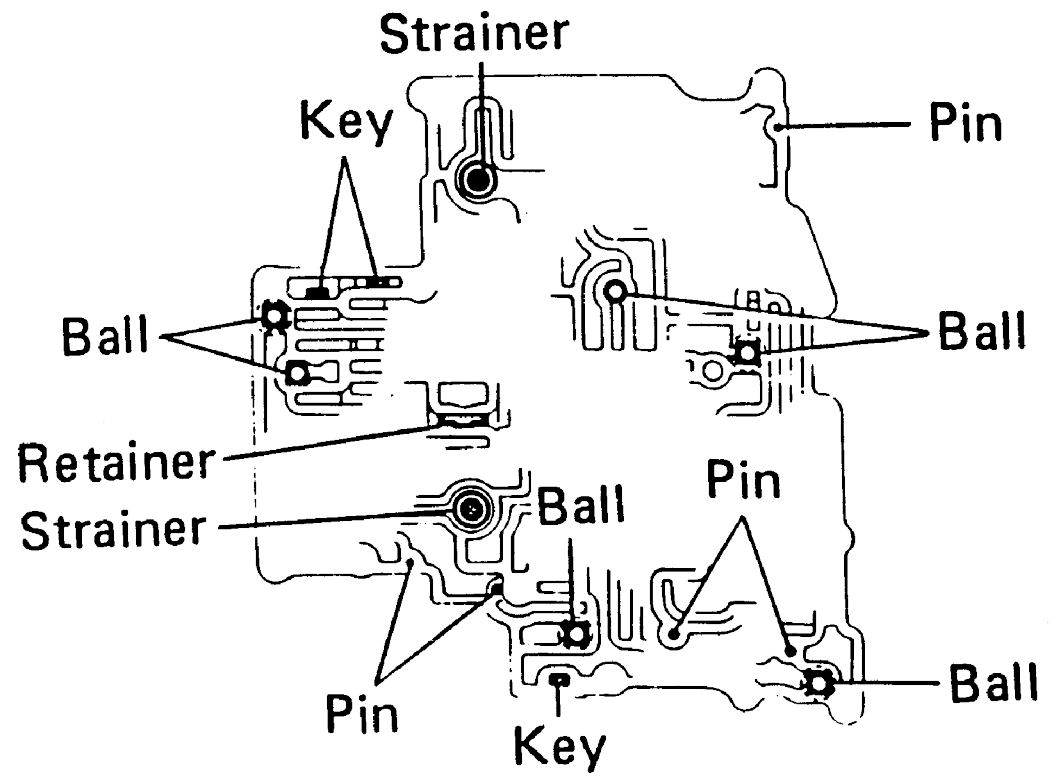
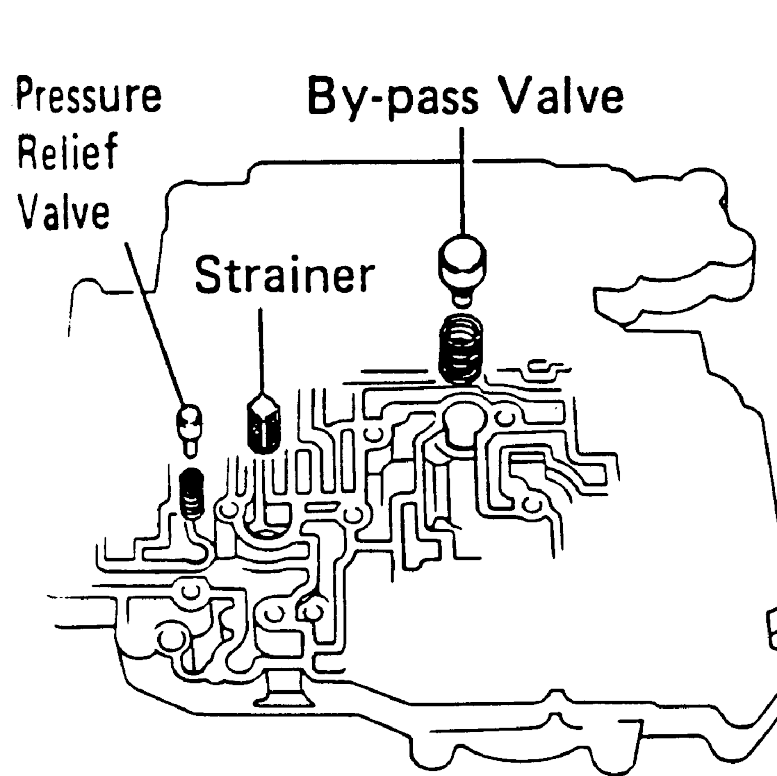

Transmission Type ..... 240E/240L/241/A244E/A245E/A246E  
Checkball Locations 240L 1985-Up

Rebuilder's Kwik  
Reference Guide

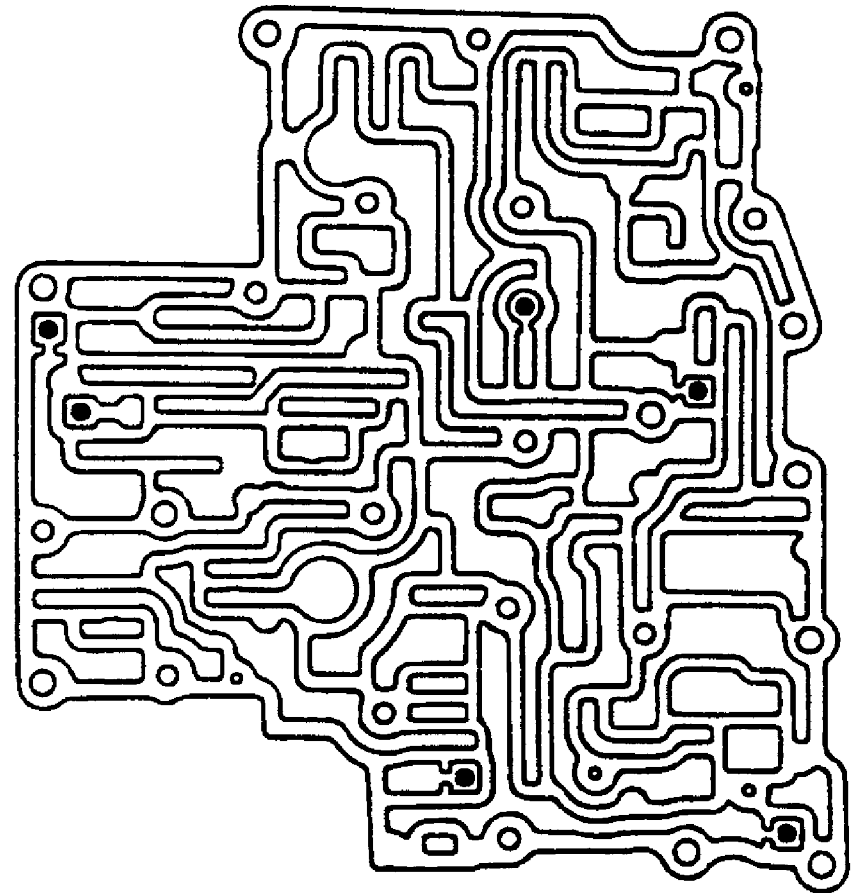
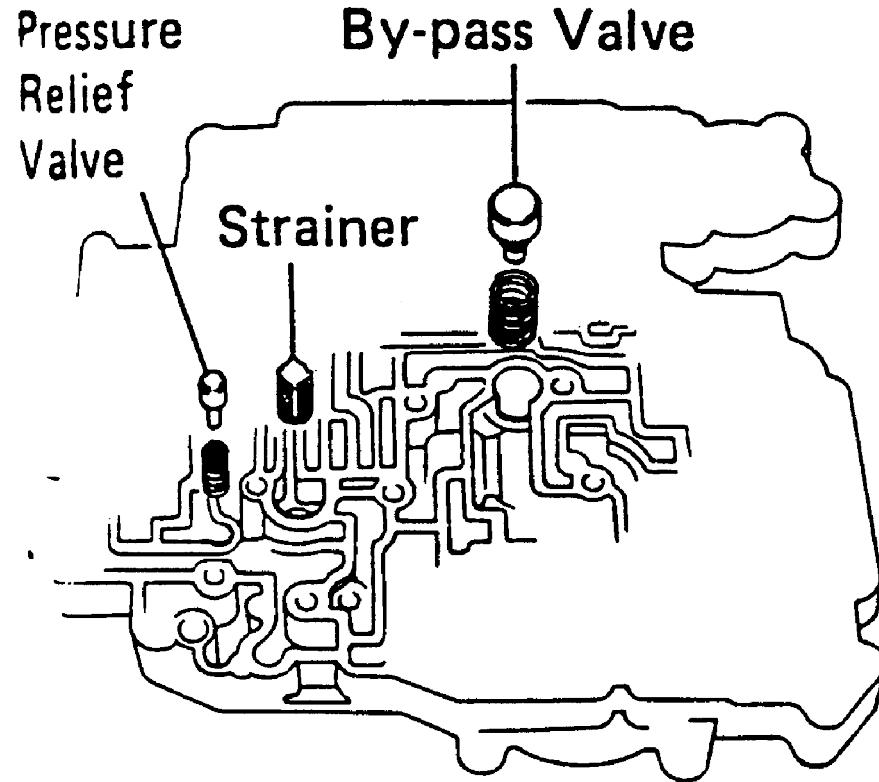

Transmission Type ..... 240E/240L/241/A244E/A245E/A246E

Rebuilder's Kwik  
Reference Guide



Checkball Locations 240L, 241H 1985-Up

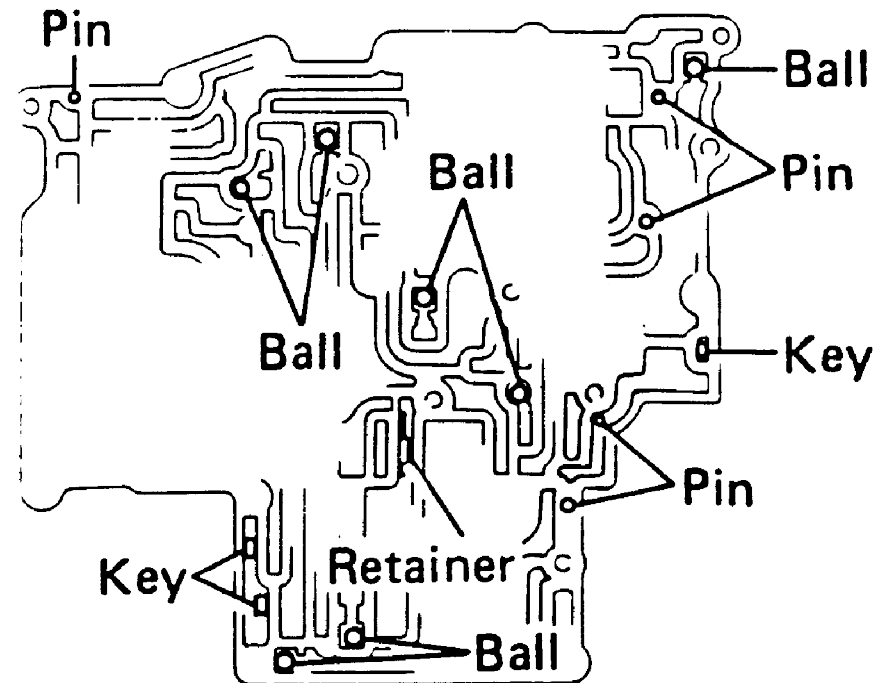
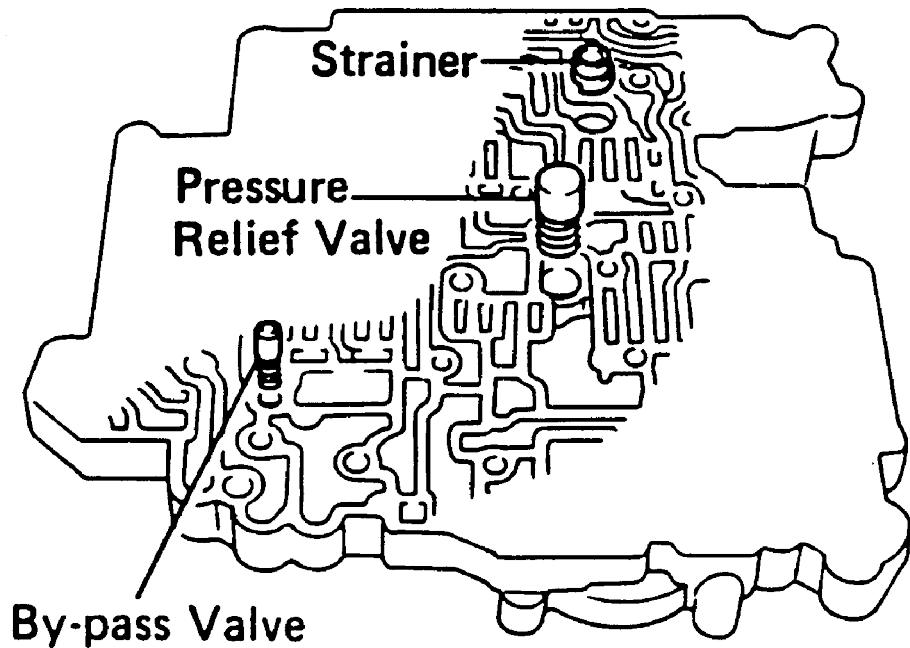

Transmission Type ..... 240E/240L/241/A244E/A245E/A246E

Rebuilder's Kwik  
Reference Guide



### Checkball Locations 241H

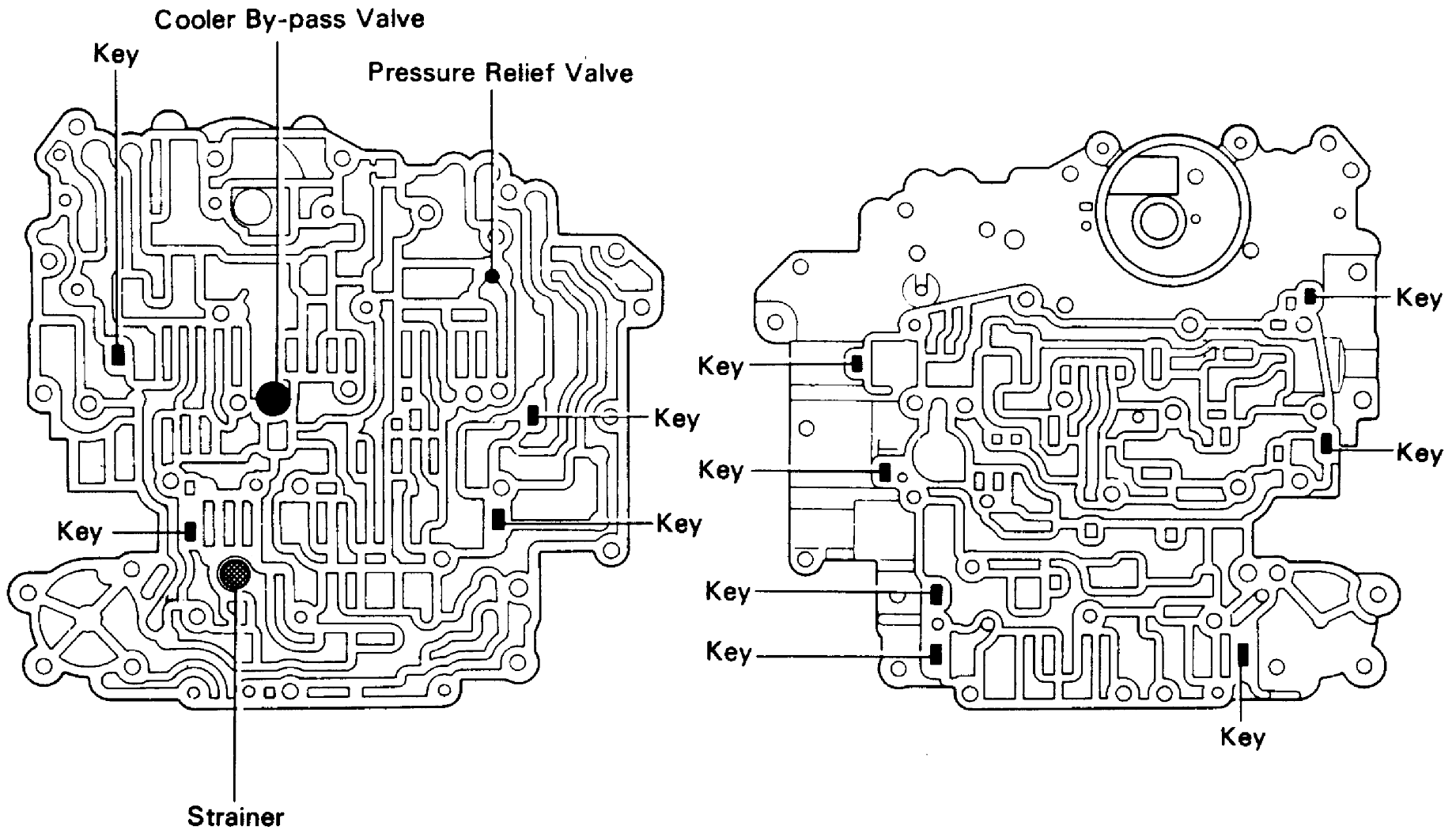



Transmission Type ..... 240E/240L/241/A244E/A245E/A246E

Rebuilder's Kwik  
Reference Guide



### Checkball Locations 241H

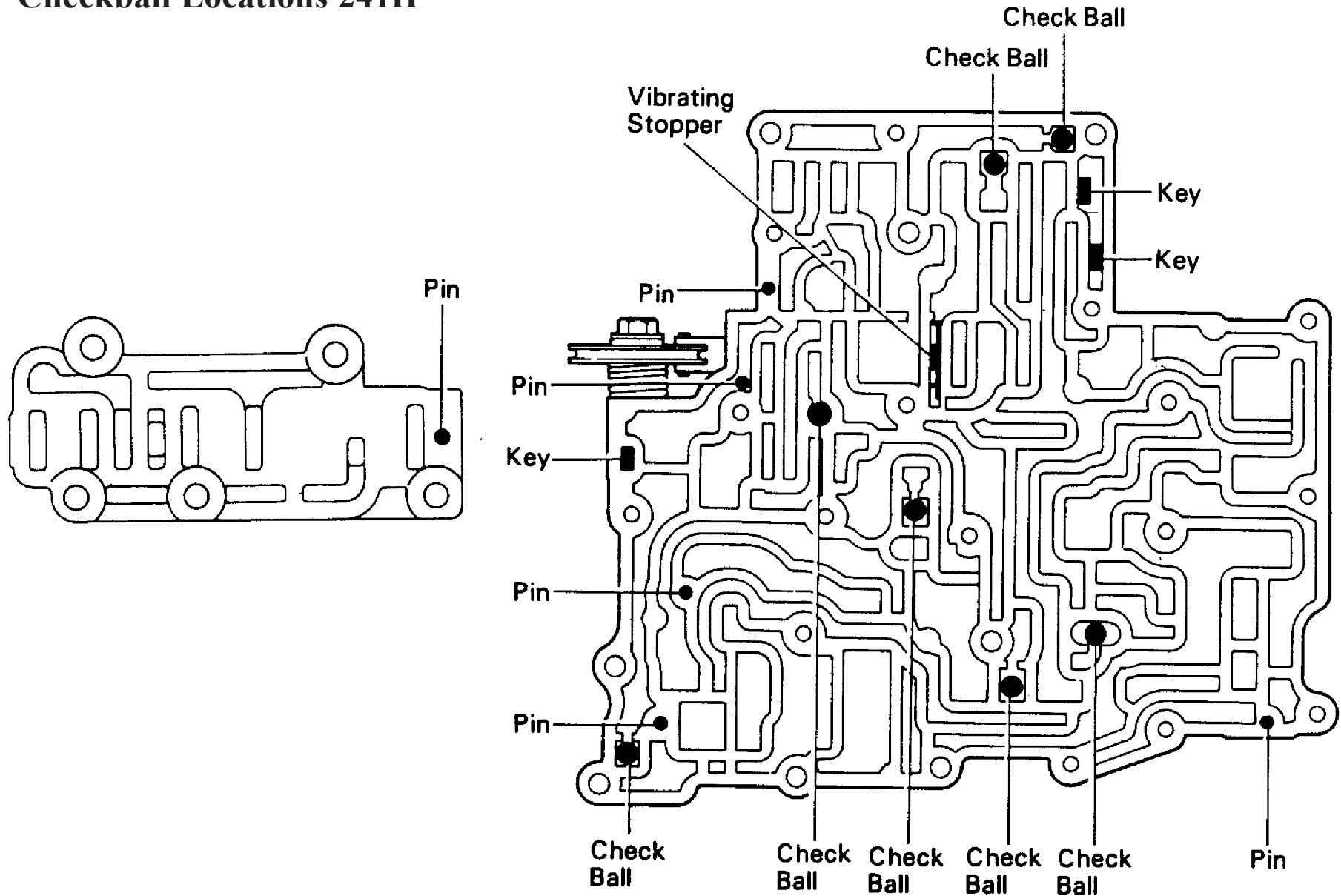

Transmission Type ..... 240E/240L/241/A244E/A245E/A246E

Checkball Locations 241E, 244E

Rebuilder's Kwik  
Reference Guide

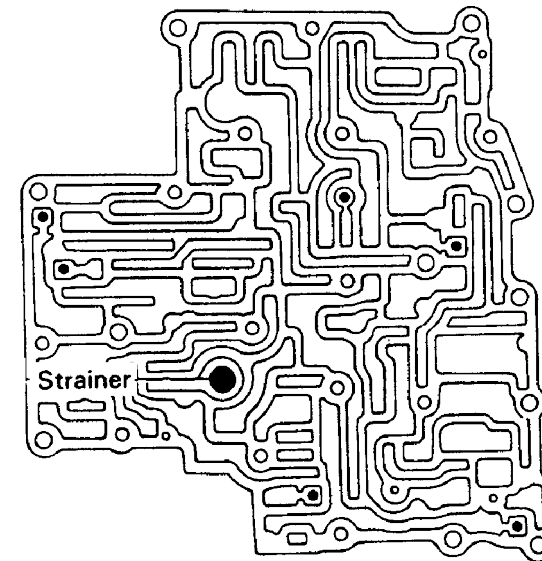
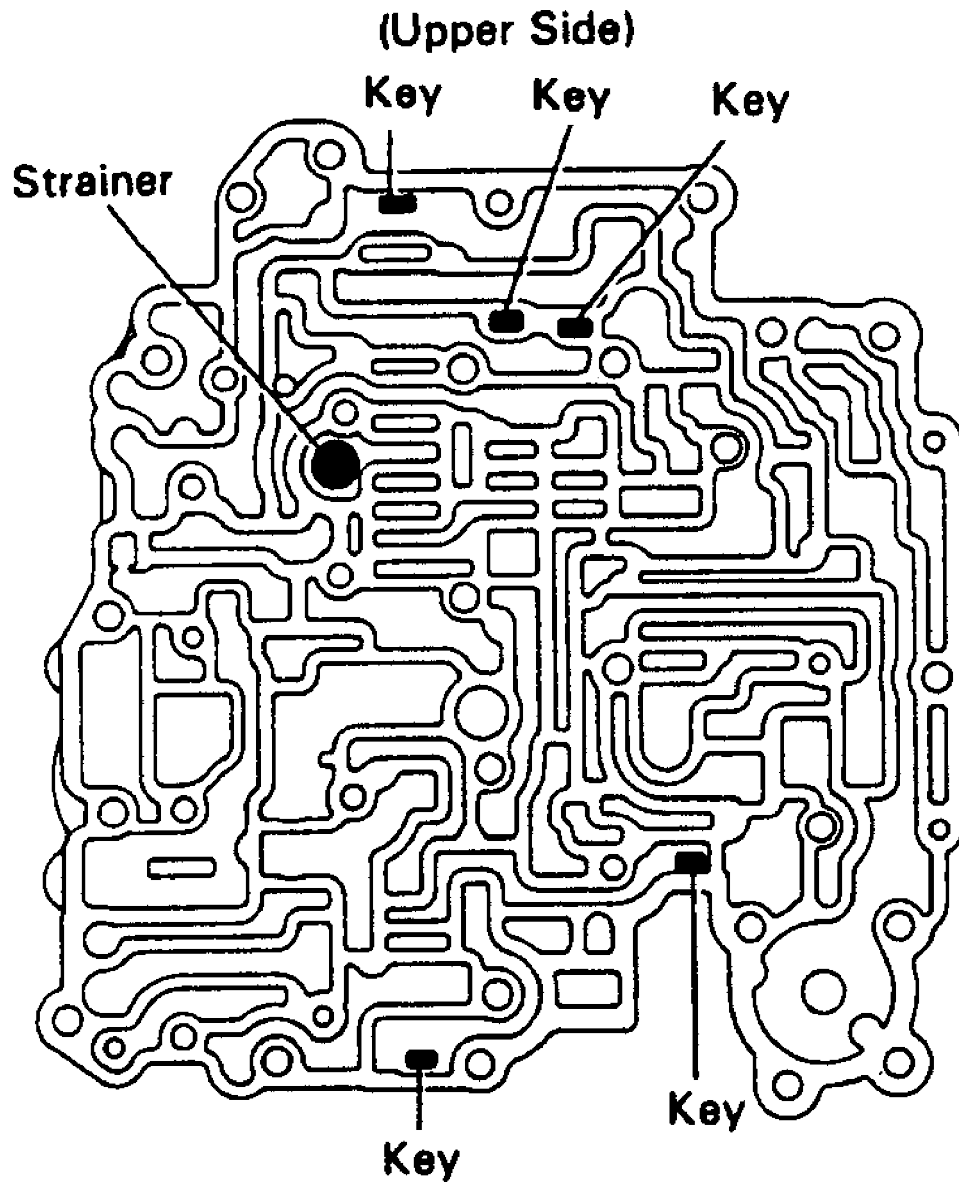

(Lower Side)

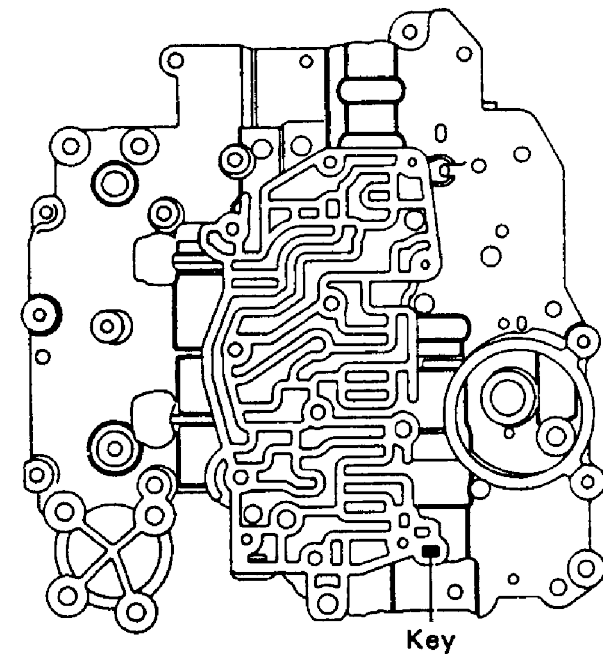

Transmission Type ..... 240E/240L/241/A244E/A245E/A246E

Rebuilder's Kwik  
Reference Guide



### Checkball Locations 245E

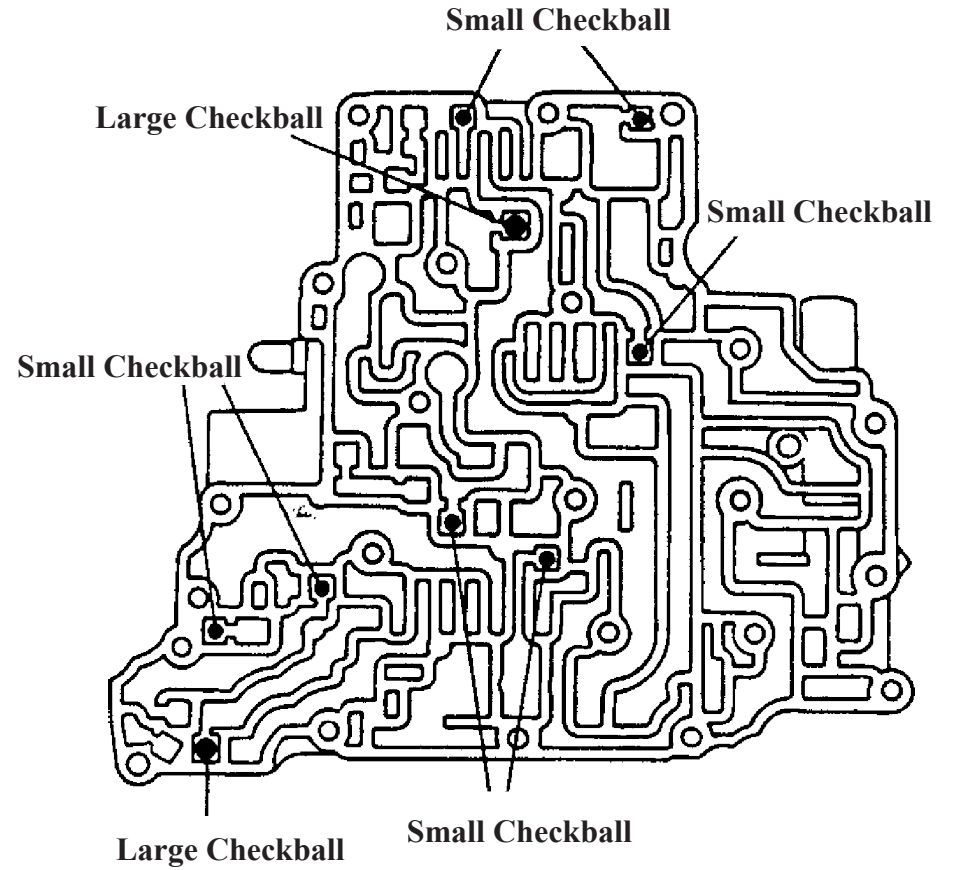
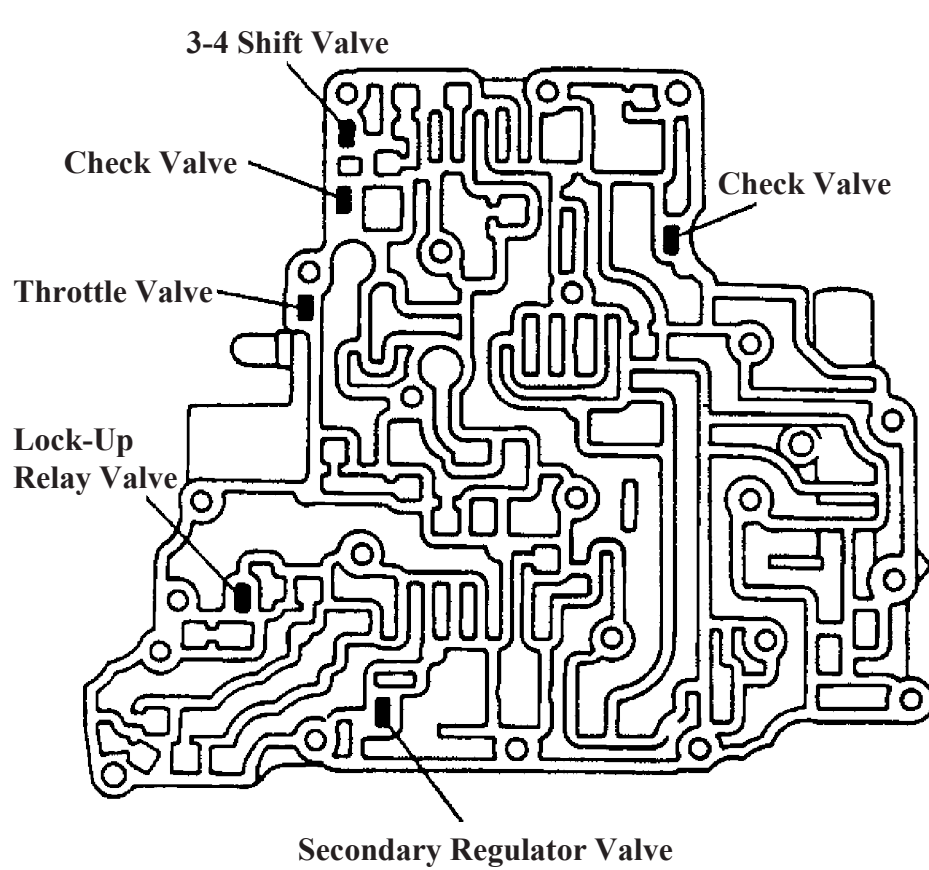

Transmission Type ..... 240E/240L/241/A244E/A245E/A246E

Rebuilder's Kwik  
Reference Guide



### Checkball Locations 245E Lower Valve Body

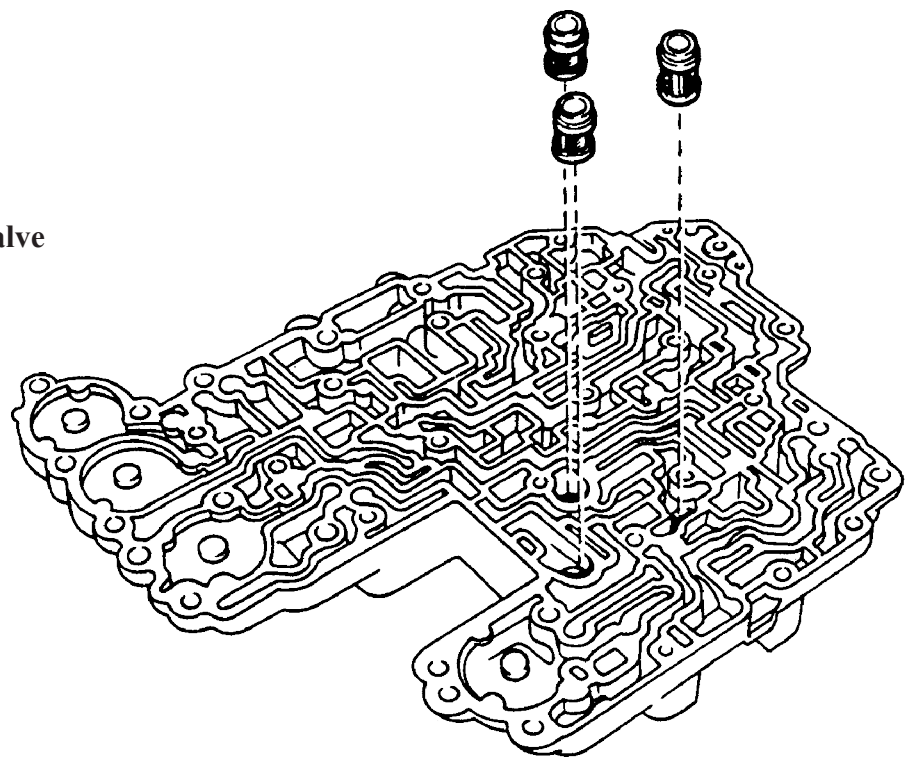
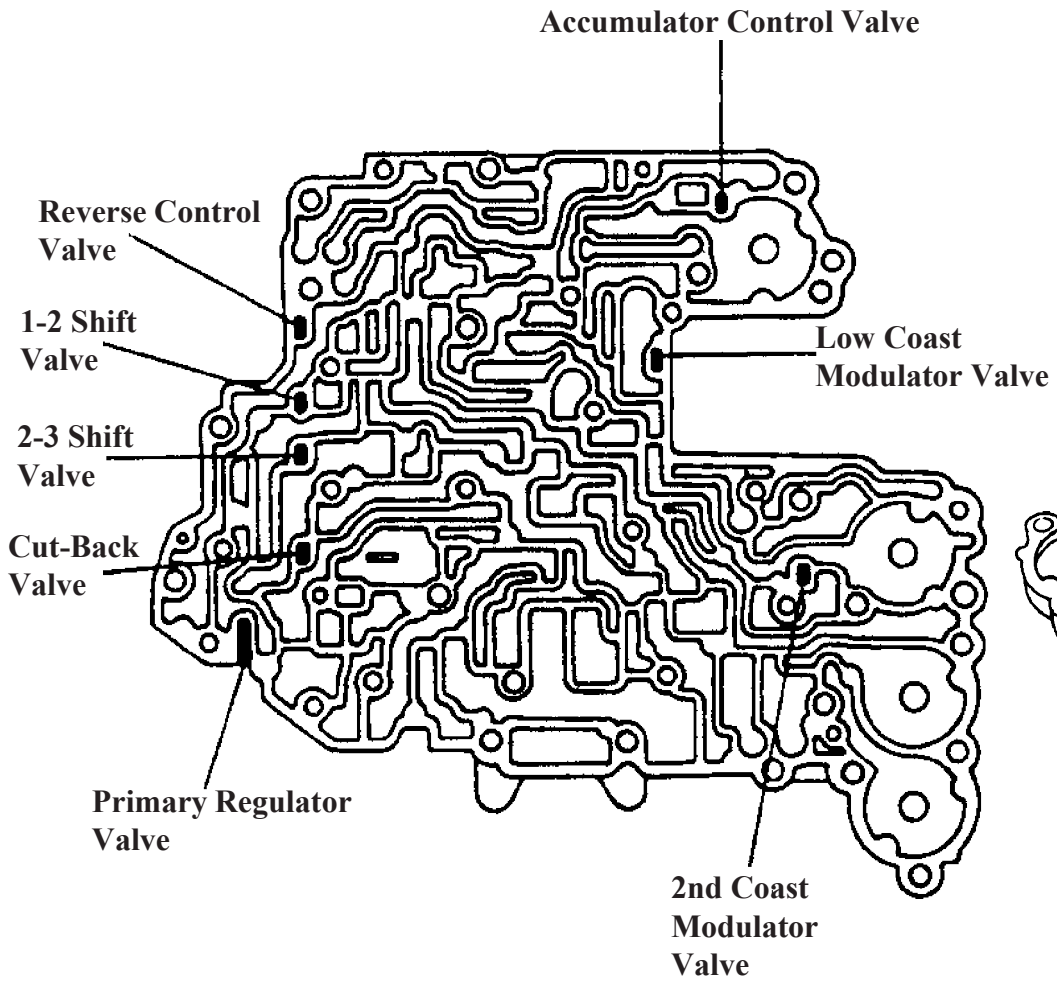



### Checkball Locations 245E Lower Valve Body

